

Name: _____

Partners: _____

Date: _____

Deflection of Electrons in an Electric Field

Purpose

In this lab, we use a Cathode Ray Tube (CRT) to measure the effects of an electric field on the motion of a charged particle, the electron. **Re-read pages 661-664 in your text.**

Theory

A charged particle experiences a force when it is in a region where there exists an electric field. From the definition of the electric field, this force is given by Equation 1.

$$\vec{F} = q\vec{E} \quad (1)$$

where F is the force exerted on the charged particle, q is the charge of the particle and E is the electric field. When an electron ($q = -e$) is in an electric field, the electron experiences a force in the direction opposite of the electric field. To examine these effects, we use a CRT. Enclosed within the cathode ray tube is an electron gun, Figure 1, which will be used to produce electrons with given energy.

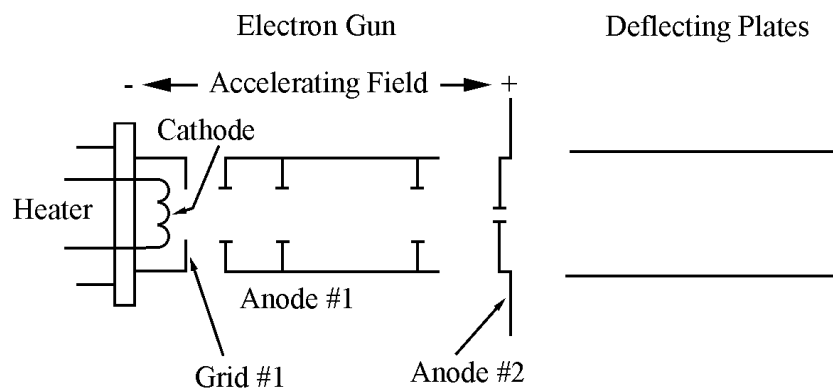

Figure 1: A cross-section of the electron gun inside the cathode ray tube.

Electrons are generated at a heated cathode, seen in the far left of Figure 1. When the cathode is heated, electrons are boiled from the surface; much like water molecules are “boiled” off of the surface of heated water. If we bias Grid 1 positive with respect to the cathode, we create an electric field that pushes the electrons toward Grid 1. The larger the bias, the larger the electric field and the number of electrons pulled from the cathode’s surface increases. The remainder of the electron gun is a series of plates and grids, used to control the velocity of the electrons when they leave the electron gun and the focus of the electron beam created by the electron gun. An open CRT is available, should you like to examine it more closely. Please be careful with the open CRT’s, so that they will be available to future students as well.

At the cathode, the electrons are initially at rest. By applying a potential difference V_{acc} , between the cathode and Anode 2, an electric field, given by Equation 2, is established between the cathode and Anode 2.

$$E_x^{accel} = -\frac{dV}{dx} = -\frac{V_{acc}}{\Delta x} \quad (2)$$

By replacing the derivative with the voltage difference divided by Δx , the total distance between the cathode and Anode 2, we find the average value of the field (rather than the local value). These relationships between voltage differences and electric fields will be explored fully in Chapter 25, but Equation (2) introduces the essential point.

The electrons at the cathode are sitting in an electric field, which means that they must experience a force given by Equation 1. Since the cathode ray tube is evacuated, there are essentially no molecules inside the glass case. As such, the electrons will not collide with any particles and energy is conserved. Since energy is conserved, what is the kinetic energy of the electrons as they pass through Anode 2, after traveling a distance Δx ?

Using your previous result, show that as the electrons leave the electron gun and enter the deflecting plates, have a velocity given by Equation 3.

$$v_x = \sqrt{\frac{2eV_{acc}}{m}} \quad (3)$$

Once the electrons leave the electron gun, we will use electric fields to “steer” the electron beam. To do this, we create a uniform electric field in the region between the deflecting plates by applying a voltage, V_d , across the plates, as seen in Figure 2. The electric field beyond the plates is essentially zero.

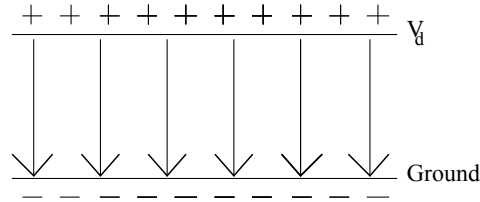

Figure 2: The electric field established in part 1 of the lab.

The strength of the electric field is given by

$$E_y^{\text{deflect}} = -\frac{dV}{dy} = -\frac{V_d}{d} \quad (4)$$

Again, we get the *average* field by replacing the derivative with the voltage difference divided by d , the distance between the plates. However, for large, parallel plates we expect that the field will be fairly uniform, so that the average field and the local field are quite close in value. This electric field will exert a force on the electron, opposite the direction of the arrows in Figure 2, causing the trajectory of the electron to be altered, as seen in Figure 3.

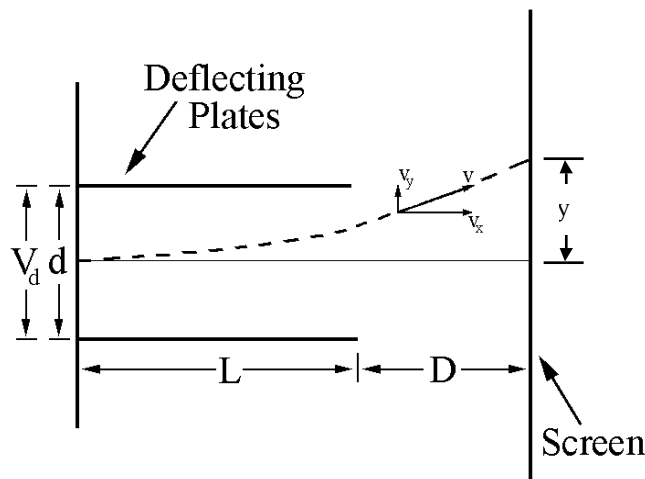

Figure 3

Using Newton’s second law and the kinematic equations, you should be able to show that the distance the electron is deflected on the screen is given by Equation 5.

$$y = \frac{eE_y^{\text{deflect}}L}{mv_x^2} \left(D + \frac{L}{2} \right) \quad (5)$$

Using Equations 4 and 5, we can write the horizontal deflection of the electron in terms of easily measured quantities.

$$y = \frac{V_d L}{2dV_{acc}} \left(D + \frac{L}{2} \right) \quad (6)$$

Procedure

The apparatus will be pre-wired, as described at the top of the next page. Examine the wiring, making sure that it agrees with what is described below. Once you think it is correct, call the instructor over to look at it ***before*** turning any power supply on. The circuit diagram for the CRT control box (the aluminum box at your station) is seen below, in Figure 4.

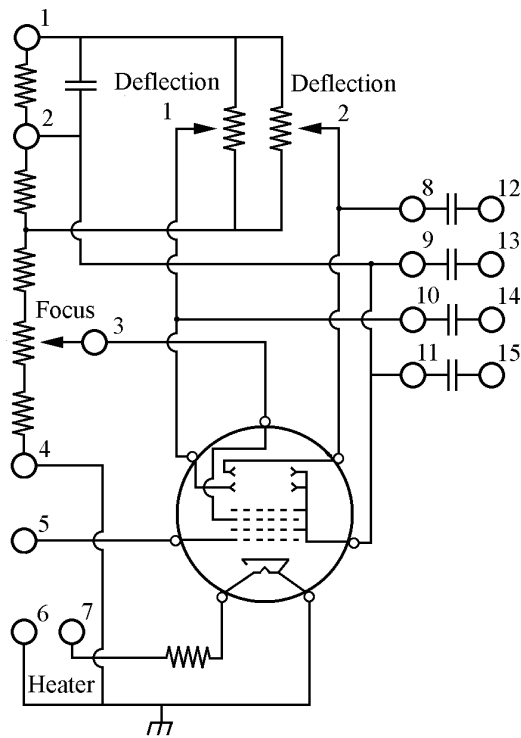

Figure 4

All of the voltages needed in this lab are produced by the HeathKit Regulated power Supply, Model IP-32.

1. The binding post to the far left on the power supply should be connected to binding post 5 (yellow) on the aluminum box. This controls the intensity of the electron beam and can be adjusted using the knob on the left hand side of the power supply.
2. The binding post labeled common and ground on the power supply should all be connected to binding post 4 (black) on the CRT control box. Additionally, this post should be connected to the instrument ground at your station.
3. The binding post labeled 6.3 Vac on the power supply should be connected to the binding posts 6 and 7 (green) on the CRT control box.
4. The red post to the far right of the power supply should be connected to binding post 1 on the CRT control box. This controls the accelerating voltage (field) for the electron gun. This is controlled using the knob on the right of the power supply.
5. Binding post 12 on the CRT control box should initially be connected to post 13, and binding post 14 should be connected to post 15.
6. The accelerating voltage (V_{acc}) is the potential difference between binding post 2 and 5 on the CRT control box.

Once everything is properly connected and has been checked by the instructor or TA, turn the power supply to *standby* position for *thirty seconds* and *then* to the on position.

You should see a green spot on the screen. If not, increase the accelerating voltage by turning the knob on the right of the power supply clockwise. Once you see a green spot, adjust the focus using the knob labeled *Focus* on the CRT control box until you observe a clear point.

The knobs labeled *Deflecting 1* and *Deflecting 2* on the CRT control box are used to control the strength of the deflecting electric field. Remove the wire connecting posts 14 and 15. The deflecting voltage can be adjusted by turning the knob labeled *Deflecting 1*. As you adjust *Deflecting 1*, **measure** the deflecting voltage by connecting a voltmeter to post 10 and 11 and observe the motion of the spot on the screen. Replace this wire and repeat the process with *Deflecting 2*. In this case, you will remove the wire connecting posts 12 and 13 and **measure** the deflecting voltage across post 8 and 9. In either case, you will **measure** the accelerating voltage between posts 5 and 2.

You will take data using whichever configuration gives you the greatest beam deflection. Voltages can be measured using the digital multimeter. Make sure that the voltmeter is set on DCV to read at least 500 V. You will then change the accelerating voltage by 10 – 20 % and repeat the experiment.

Questions

1. Why are the two graphs you plotted using your deflected voltage and displacement not the same?
2. Calculate the velocity of an electron in, and the time the electron spends between, the deflecting plates. Record any measurements that you had to make.
3. Using Newton's second law and the kinematic equations, verify that Equation 5 is correct.

Initiative

Conclusions